

DX3-3000S Sub-Arctic Solar Street Light

(Designed for Canada and other cold climate applications)

An alternative and clean outdoor lighting solution for anywhere, anytime

Every year, millions of street lights are installed worldwide. The demand for street lighting is creating a significant impact on the available electrical generation. Our solution removes the lighting from the grid using solar power or reduces the power demand using our highly efficient LED lights. Our solar lighting concept is a viable, proven alternative to traditional lighting methods.

DX3 Enterprises Ltd. manufactures high efficiency, high output LED arrays and Intelligent Hybrid Driver Boards (IHDB). We offer the first fully-integrated, intelligent, hybrid multi-source powered LED Street Light for anytime, anywhere installation, without the need for electricity. The solar panel array is aimed towards the sun at the optimal angle for maximum power. The DX3-3000 Sub-Arctic solar array is mounted directly onto the light pole. It requires two large solar panels to power the light during the winter months in cold climate regions.

Our products are manufactured with the very latest technologies including light weight, electrically robust, Lithium Polymer batteries. Our main components are custom designed & assembled in Canada including domestic LED & driver board manufacturing.

KEY FEATURES

- **WORKS EFFECTIVELY AT TEMPERATURES RANGING FROM -40C to +80C**
- **FLEXIBLE MODEL SELECTION FOR ADAPTING VARIOUS SOLAR RADIATION LEVELS**
- **ADVANCED POWER MANAGEMENT FEATURES FOR SUMMER / WINTER OPTIMIZATION**
- **INSTALL AND FORGET - OVER 3 YEARS OF RELIABLE MAINTENANCE FREE OPERATION**
- **POWDER COATED ALUMINUM & STEEL CONSTRUCTION FOR DURABILITY**

BENEFITS

- **LOW CAPITAL COST - NO POWER CABLES, TRENCHES, POWER SYSTEM REQUIRED**
- **ZERO OPERATING AND MINIMAL ROUTINE MAINTENANCE COST**
- **IMPROVED SAFETY FACTOR – NO GRID CONNECTION**
- **COMPACT SINGLE PIECE DESIGN**
- **FAST & SIMPLE INSTALLATION – REDUCED LABOUR & INSTALLATION COST**

PACKAGING

To properly package the integrated DX3-3000S Sub-Arctic solar street light system we custom manufacture our street light head to contain all the major components, this includes the battery and driver boards that are located inside the light housing. The DX3-3000S Sub-Arctic comes with a special designed pole for easy mounting of the solar array.



For more information on this or other products & services,
Please visit our Website:

www.DX3LTD.com

HEAD OFFICE: CANADA – WEST

Unit #109, 117 Pembina Road
Sherwood Park, AB, Canada T8H 0J4

Phone: 780-467-0303

Toll Free: 866-796-0303

Fax: 866-821-3732

E-mail: sales@dx3ltd.com



*

DX3-3000S Sub-Arctic Specifications

*Information subject to change without notice.

DX3 ENTERPRISES LTD. LED ARRAY Specifications

DX3 ENTERPRISES LTD. Model:	DX3-3000S
LED Selection Option:	32 LED array, 2000 – 3400 Lumens; DX3-LCGC2-32 (Cree) OR DX3-LRPW2-32 (Rebel)
Watts:	Nominal 30W, Factory adjustable 20W to 34W
Warranty:	2 year limited warranty on material and workmanship
LED Life span:	50,000+ Hours

DX3 ENTERPRISES LTD. DRIVER BOARD Specifications

Driver Type:	DX3 ENTERPRISES LTD. designed charge control and LED driver board, micro-procDX3or configurable, PWM dimming, high efficiency integrated system.
Inputs:	Nominal 17.5VDC from Solar Panel & photo cell signal input
Power Source:	BATTERY 12.8VDC
Warranty:	2 year limited warranty on material and workmanship

SOLAR PANEL Power Selection

Solar Panel Power Options:	280W (140W x2)
Solar Panel Driver:	DX3 ENTERPRISES LTD. ESD Integrated Maximum Power Point Tracking (MPPT) Solar Power Optimization. (DUAL driver board setting)
Solar Panel Mounting:	Includes tubular attachment sleeve for connection to top of lamp post and mounting frame for secure attachment of solar panels. Orientation is adjustable towards sun.
Warranty:	1 year limited warranty on material and workmanship

BATTERY SPECIFICATION

Battery Charge Driver:	DX3 ENTERPRISES LTD. ESD Integrated Optimized Battery Charging Control (OBCC), with intelligent power source selection
Type:	Lithium Polymer (LP), Light Weight, Fully Sealed
Operating Temp:	-40C to +80C
Capacity:	90 Ah
Autonomous:	Time Greater than 3 operating days (1 Day = 10 Nighttime Hours)
Weight:	12.7kg (28lbs)
Lifespan:	3 – 5 years
Warranty:	1 year limited warranty on material and workmanship

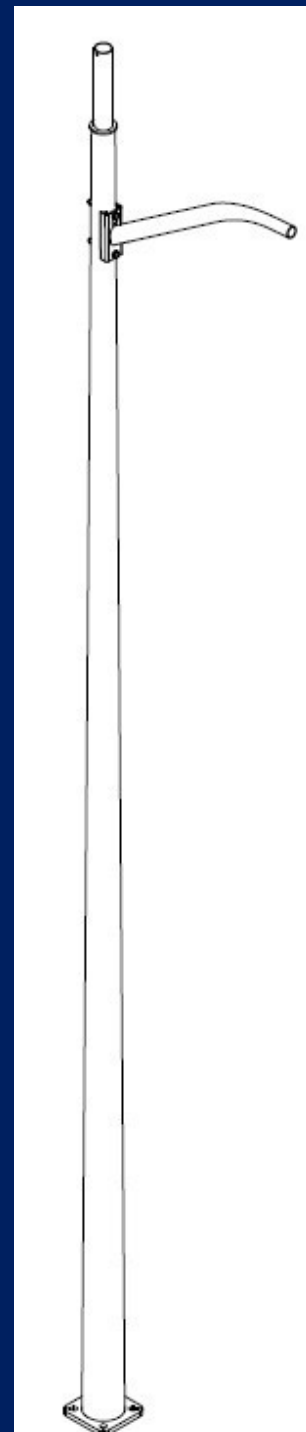

For more information on this or other products & services,

Please visit our Website:

www.DX3LTD.com

HEAD OFFICE: CANADA – WEST

Unit #109, 117 Pembina Road
Sherwood Park, AB, Canada T8H 0J4

Phone: 780-467-0303

Toll Free: 866-796-0303

Fax: 866-821-3732

E-mail: sales@dx3ltd.com



POLE SPECIFICATION

Design: Pole supporting one fixture (3.6 sqft EPA & 82 Lbs) and one solar panel (59.5"x54" & 150 Lbs) is designed for 160k ph wind loading (including AASHTO gust factor of 1.3) in accordance with AASHTO Standard Specifications For Highway Signs, Luminaries, and Traffic Signals.

Height: 25'-0" light height, 26'-6" total pole height

Base Bolt Pattern: 11 to 11-1/2"

CONSTRUCTION - DX3-3000S Sub-Arctic Street Light

Housing Aluminum Shell over Skeletal Structure, external solar panel array mounted on top of street pole with 360 degree swivel and vertical tilt. Swivel mount is directly connected to light head.

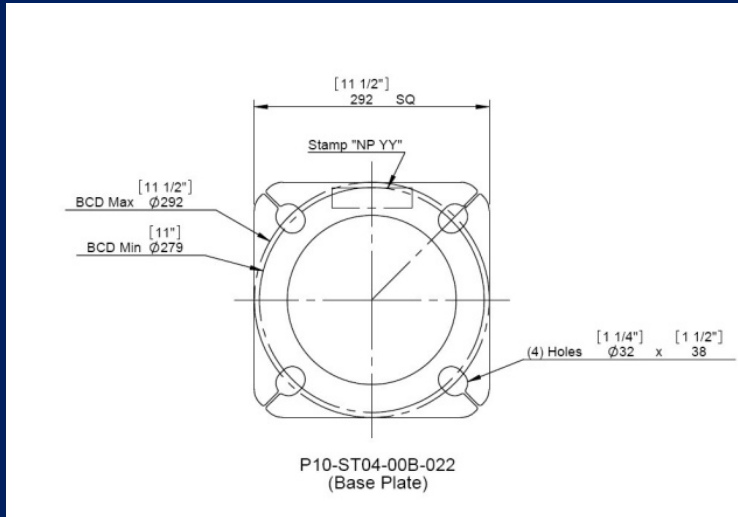

For more information on this or other products & services,
Please visit our Website:

www.DX3LTD.com

HEAD OFFICE: CANADA – WEST

Unit #109, 117 Pembina Road
Sherwood Park, AB, Canada T8H 0J4

Phone: 780-467-0303

Toll Free: 866-796-0303

Fax: 866-821-3732

E-mail: sales@dx3ltd.com

